

1.8 μ A Quiescent Current, 15V, 300mA Synchronous Step-Down DC/DC Converter

FEATURES

- **Ultralow Quiescent Current: 1.8 μ A**
- **Synchronous Rectification: Efficiency Up to 95%**
- **Wide V_{IN} Range: 2.5V to 15V**
- **Wide V_{OUT} Range: 0.6V to 13.8V**
- **300mA Output Current**
- **User-Selectable Automatic Burst Mode[®] or Forced Continuous Operation**
- Accurate and Programmable RUN Pin Threshold
- 1.2MHz Fixed Frequency PWM
- Internal Compensation
- Power Good Status Output for V_{OUT}
- Available in Thermally Enhanced 3mm \times 3mm \times 0.75mm, 10-Pin DFN and 10-Pin MSOP Packages

APPLICATIONS

- Remote Sensor Networks
- Distributed Power Systems
- Multicell Battery or SuperCap Regulator
- Energy Harvesters
- Portable Instruments
- Low Power Wireless Systems

DESCRIPTION

The **LTC[®]3103** is a high efficiency, monolithic synchronous step-down converter using a current mode architecture capable of supplying 300mA of output current.

The LTC3103 offers two operational modes: automatic Burst Mode operation and forced continuous mode allowing the user the ability to optimize output voltage ripple, noise and light load efficiency. With Burst Mode operation enabled, the typical DC input supply current at no load drops to 1.8 μ A maximizing the efficiency for light loads. Selection of forced continuous mode provides very low noise constant frequency, 1.2MHz operation.

Additionally, the LTC3103 includes an accurate RUN comparator, thermal overload protection, a power good output and an integrated soft-start feature to guarantee that the power system start-up is well controlled.

LT, LT, LTC, LTM, Burst Mode, Linear Technology and the Linear logo are registered trademarks of Linear Technology Corporation. All other trademarks are the property of their respective owners.

TYPICAL APPLICATION

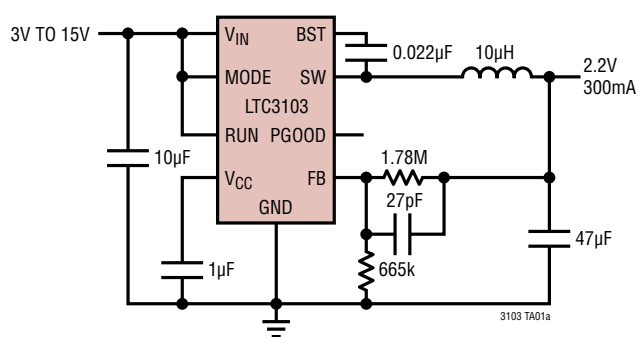

Efficiency vs Output Current

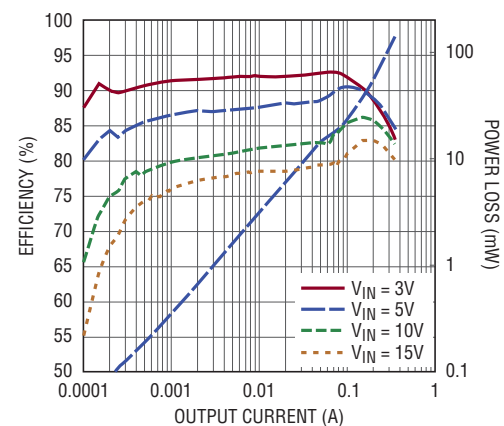

3103 TA01b

LTC3103

ABSOLUTE MAXIMUM RATINGS (Note 1)

V_{IN}	-0.3V to 18V	Operating Junction Temperature Range	
SW	-0.3V to ($V_{IN} + 0.3V$)	(Notes 2, 3)	-40°C to 125°C
FB	-0.3V to 6V	Storage Temperature Range	-65°C to 150°C
BST	(SW - 0.3V) to (SW + 6V)	Lead Temperature (Soldering, 10 sec)	
RUN, MODE	-0.3V to V_{IN}	MSE Only	300°C
V_{CC} , PGOOD	-0.3V to 6V		

PIN CONFIGURATION

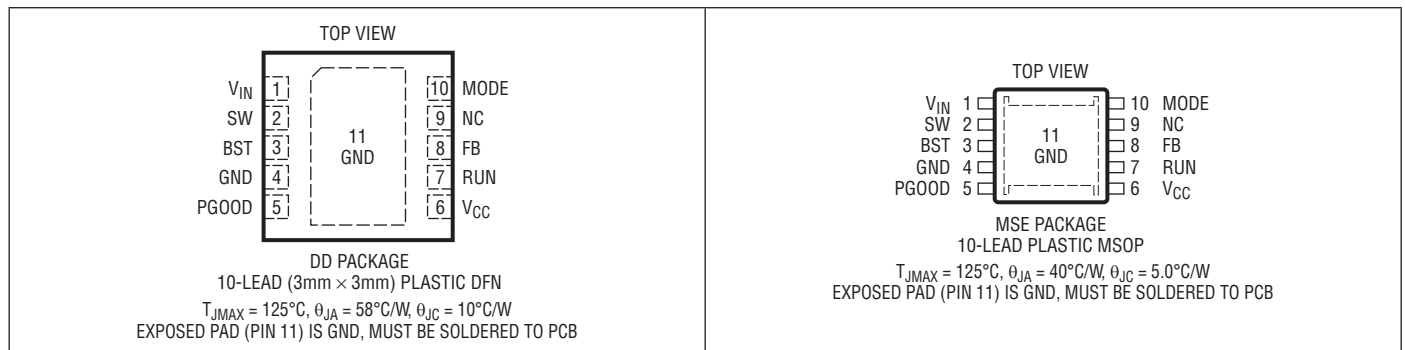

ORDER INFORMATION <http://www.linear.com/product/LTC3103#orderinfo>

LEAD FREE FINISH	TAPE AND REEL	PART MARKING*	PACKAGE DESCRIPTION	TEMPERATURE RANGE
LTC3103EDD#PBF	LTC3103EDD#TRPBF	LFXH	10-Lead (3mm × 3mm) Plastic DFN	-40°C to 125°C
LTC3103IDD#PBF	LTC3103IDD#TRPBF	LFXH	10-Lead (3mm × 3mm) Plastic DFN	-40°C to 125°C
LTC3103EMSE#PBF	LTC3103EMSE#TRPBF	LTFXJ	10-Lead Plastic MSOP	-40°C to 125°C
LTC3103IMSE#PBF	LTC3103IMSE#TRPBF	LTFXJ	10-Lead Plastic MSOP	-40°C to 125°C

Consult LTC Marketing for parts specified with wider operating temperature ranges. *The temperature grade is identified by a label on the shipping container. For more information on lead free part marking, go to: <http://www.linear.com/leadfree/>. For more information on tape and reel specifications, go to: <http://www.linear.com/tapeandree/>. Some packages are available in 500 unit reels through designated sales channels with #TRMPBF suffix.

ELECTRICAL CHARACTERISTICS

The ● denotes the specifications which apply over the full operating junction temperature range, otherwise specifications are at $T_A = 25^{\circ}C$ (Note 2). $V_{IN} = 10V$ unless otherwise noted.

PARAMETER	CONDITIONS	MIN	TYP	MAX	UNITS
Step-Down Converter					
Input Voltage Range	After Start-Up	●	2.6	15	V
		●	2.5		V
Input Undervoltage Lockout Threshold	V_{IN} Rising V_{IN} Rising, $T_J = 0^{\circ}C$ to $85^{\circ}C$ (Note 4)	●	2.1	2.6	V
			2.1	2.5	V
Input Undervoltage Lockout Hysteresis	(Note 4)		0.4		V

3103fa

ELECTRICAL CHARACTERISTICS

The ● denotes the specifications which apply over the full operating junction temperature range, otherwise specifications are at $T_A = 25^\circ\text{C}$ (Note 2). $V_{IN} = 10\text{V}$ unless otherwise noted.

PARAMETER	CONDITIONS		MIN	TYP	MAX	UNITS
Feedback Voltage	(Note 5)	●	0.588	0.6	0.612	V
Feedback Voltage Line Regulation	$V_{IN} = 2.5\text{V}$ to 15V (Note 5)			0.02	0.05	%/V
Feedback Input Current	(Note 5)	●		1	20	nA
Oscillator Frequency	$T_J = 0^\circ\text{C}$ to 85°C (Note 4)	●	0.930 1	1.2 1.2	1.55 1.45	MHz MHz
Quiescent Current, V_{IN} —Active	$\text{RUN} = V_{IN}$, $\text{MODE} = 0\text{V}$, $\text{FB} > 0.612$ Nonswitching			600		μA
Quiescent Current, V_{IN} —Sleep	$\text{RUN} = V_{IN}$, $\text{FB} > 0.612$, $\text{MODE} = V_{IN}$, $T_J = 0^\circ\text{C}$ to 85°C (Note 4) $\text{RUN} = V_{IN}$, $\text{FB} > 0.612$, $\text{MODE} = V_{IN}$	●		1.8 1.8	2.6 3.3	μA μA
Quiescent Current, V_{IN} —Shutdown	$\text{RUN} = 0\text{V}$, $T_J = 0^\circ\text{C}$ to 85°C (Note 4) $\text{RUN} = 0\text{V}$	●		1 1.8	1.7 3.3	μA μA
N-Channel MOSFET Synchronous Rectifier Leakage Current	$V_{IN} = V_{SW} = 15\text{V}$, $V_{\text{RUN}} = 0\text{V}$			0.01	0.3	μA
N-Channel MOSFET Switch Leakage Current	$V_{IN} = 15\text{V}$, $V_{SW} = 0\text{V}$, $V_{\text{RUN}} = 0\text{V}$			0.01	0.3	μA
N-Channel MOSFET Synchronous Rectifier $R_{\text{DS(ON)}}$	$I_{\text{SW}} = 200\text{mA}$			0.85		Ω
N-Channel MOSFET Switch $R_{\text{DS(ON)}}$	$I_{\text{SW}} = -200\text{mA}$			0.65		Ω
Peak Current Limit		●	0.40	0.50	0.75	A
PGOOD Threshold	FB Falling, Percentage Below FB		-14	-10	-5	%
PGOOD Hysteresis	Percentage of FB			2		%
PGOOD Voltage Low	$I_{\text{PGOOD}} = 100\mu\text{A}$			0.2		V
PGOOD Leakage Current	$V_{\text{PGOOD}} = 5\text{V}$			0.01	0.3	μA
Maximum Duty Cycle		●	89	92		%
Switch Minimum Off Time ($t_{\text{OFF(MIN)}}$)	(Note 4)			65		ns
Synchronous Rectifier Minimum On Time ($t_{\text{ON(MIN)}}$)	(Note 4)			70		ns
RUN Pin Threshold	RUN Pin Rising	●	0.76	0.80	0.85	V
RUN Pin Hysteresis				0.06		V
RUN Input Current	$\text{RUN} = 1.2\text{V}$	●		0.01	0.4	μA
MODE Threshold		●	0.5	0.8	1.2	V
MODE Input Current	$\text{MODE} = 1.2\text{V}$			0.1	4	μA
Soft-Start Time	$V_{IN} = 5\text{V}$		0.7	1.4	2.5	ms

Note 1: Stresses beyond those listed under Absolute Maximum Ratings may cause permanent damage to the device. Exposure to any Absolute Maximum Rating condition for extended periods may affect device reliability and lifetime.

Note 2: The LTC3103 is tested under pulsed load conditions such that $T_J \approx T_A$. The LTC3103E is guaranteed to meet specifications from 0°C to 85°C junction temperature. Specifications over the -40°C to 125°C operating junction temperature range are assured by design, characterization and correlation with statistical process controls. The LTC3103I is guaranteed over the full -40°C to 125°C operating junction temperature range. The junction temperature (T_J) is calculated from the ambient temperature (T_A) and power dissipation (P_D) according to the formula:

$$T_J = T_A + (P_D)(\theta_{JA}^\circ\text{C/W})$$

where θ_{JA} is the package thermal impedance. Note the maximum ambient temperature consistent with these specifications is determined by specific operating conditions in conjunction with board layout, the rated package thermal resistance and other environmental factors.

Note 3: This IC includes overtemperature protection that is intended to protect the device during momentary overload conditions. The maximum rated junction temperature will be exceeded when this protection is active. Continuous operation above the specified absolute maximum operating junction temperature may impair device reliability or permanently damage the device.

Note 4: Specification is guaranteed by design.

Note 5: The LTC3103 has a proprietary test mode that allows testing in a feedback loop which servos V_{FB} to the balance point for the error amplifier.

TYPICAL PERFORMANCE CHARACTERISTICS $T_A = 25^\circ\text{C}$ unless otherwise noted

Efficiency vs Output Current

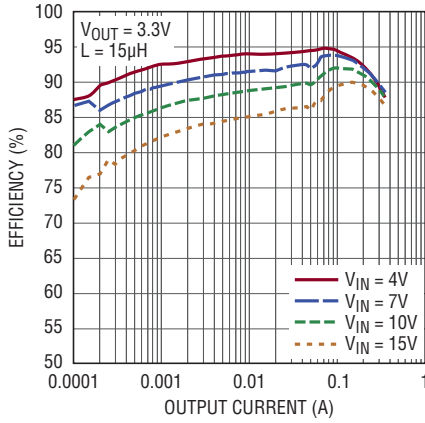

3103 G01

Efficiency vs Input Voltage (Automatic Burst Mode Operation)

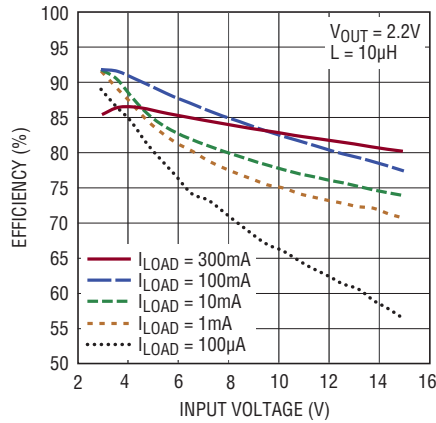

3103 G02

Application No-Load Input Current vs Supply Voltage (Automatic Burst Mode Operation)

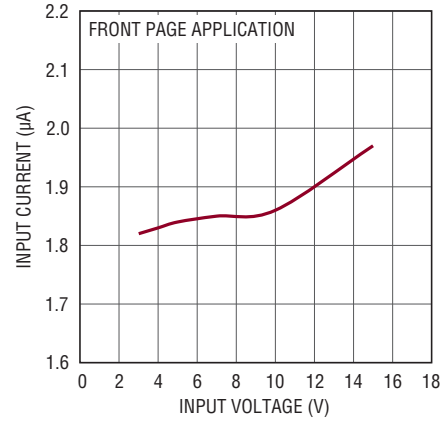

3103 G03

Efficiency vs Output Current (Forced Continuous Operation)

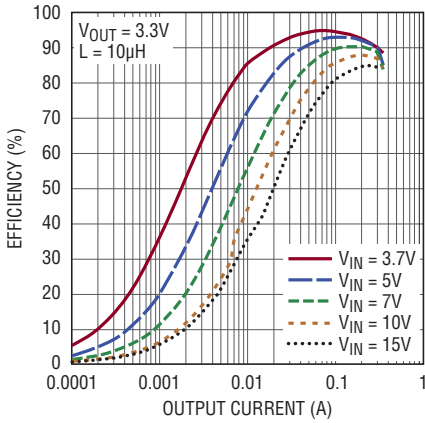

3103 G04

Efficiency vs Input Voltage (Forced Continuous Operation)

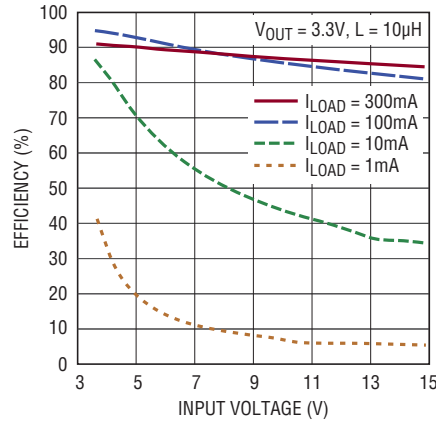

3103 G05

Application No-Load Input Current vs Supply Voltage (Forced Continuous Operation)

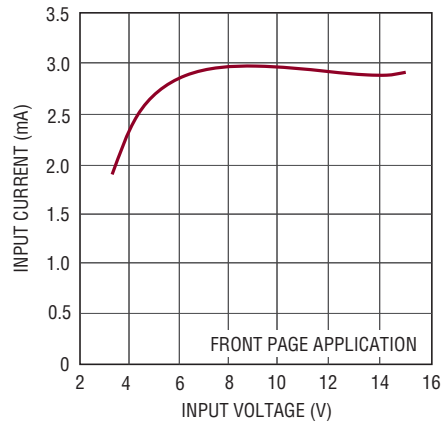

3103 G06

Feedback Voltage vs Temperature

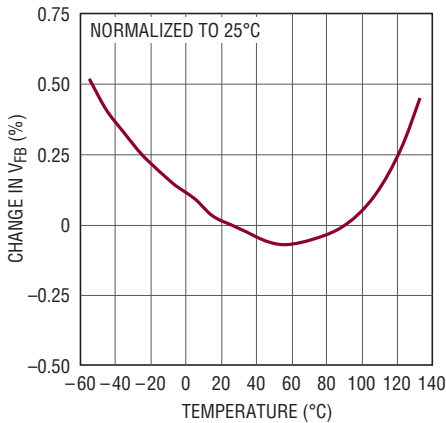

3103 G07

Oscillator Frequency vs Temperature

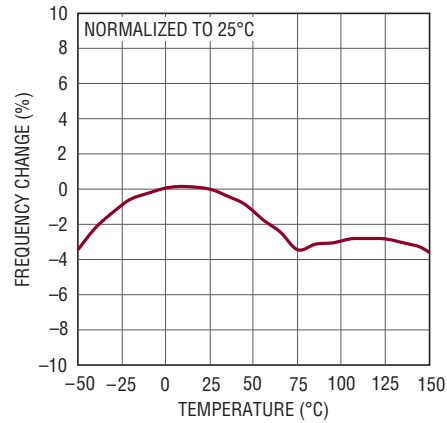

3103 G08

RDS(ON) vs Temperature

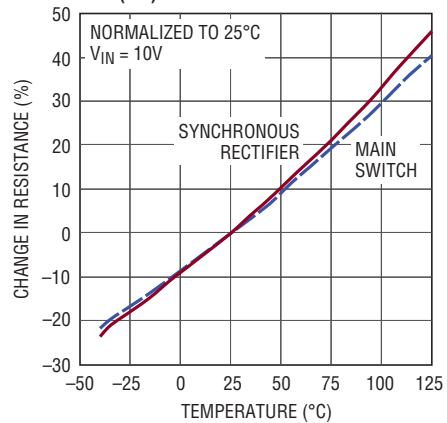

3103 G09

3103fa

TYPICAL PERFORMANCE CHARACTERISTICS $T_A = 25^\circ\text{C}$ unless otherwise noted

SW Leakage vs Temperature

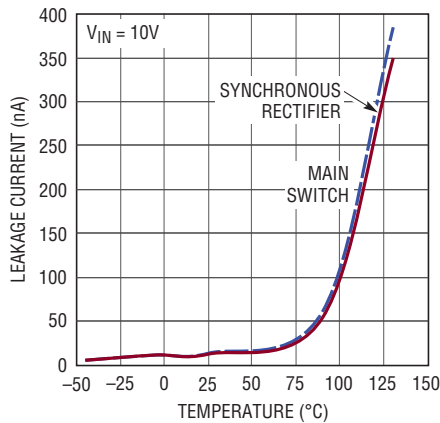

3103 G10

Peak Current Limit Change vs Temperature

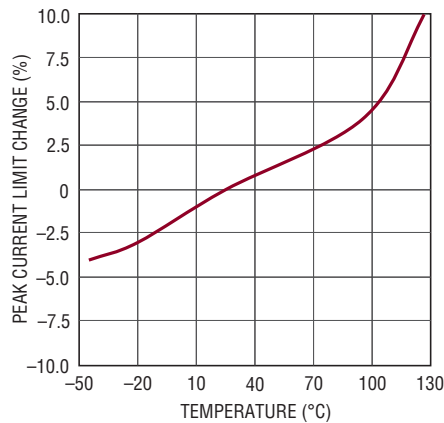

3103 G11

Application No-Load Input Current vs Temperature (Automatic Burst Mode Operation)

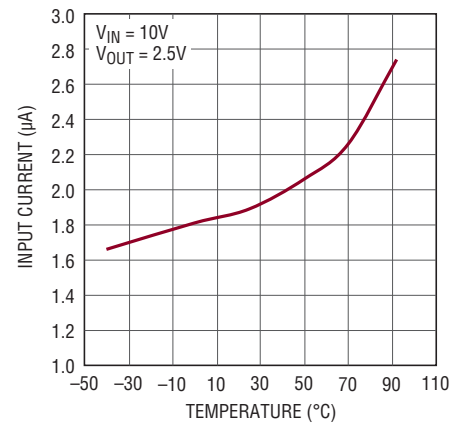

3103 G12

Automatic Burst Mode Operation

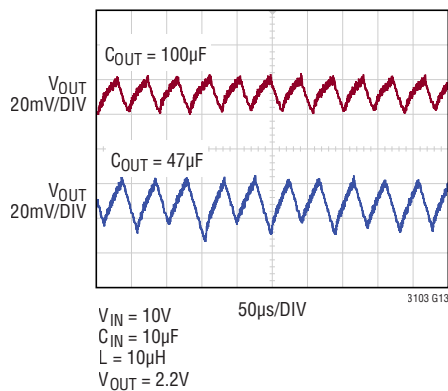

3103 G13

Forced Continuous Operation

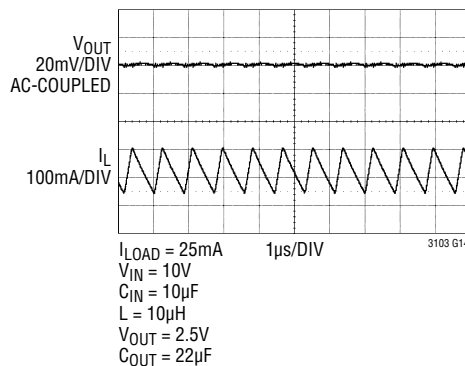

3103 G14

Start-Up into Pre-Biased Output (Automatic Burst Mode Operation)

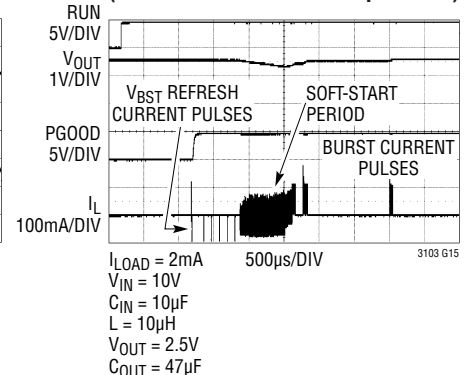

3103 G15

Start-Up into Pre-Biased Output (Forced Continuous Operation)

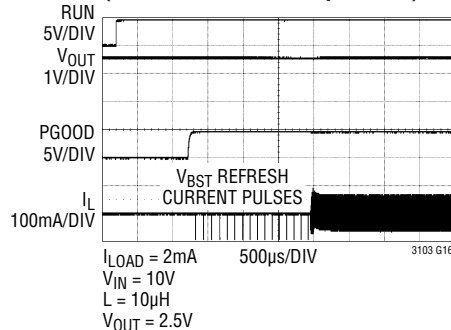

3103 G16

Start-Up from Shutdown (Automatic Burst Mode Operation)

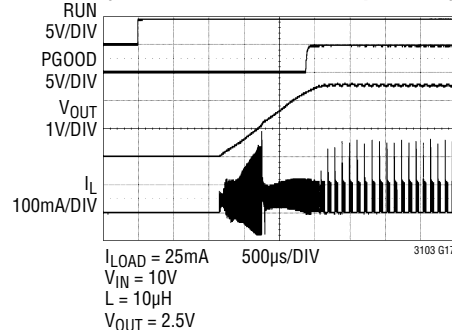

3103 G17

Start-Up from Shutdown (Forced Continuous Operation)

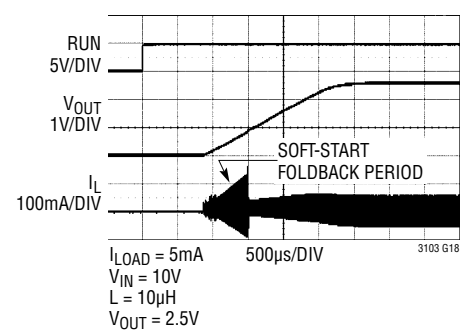

3103 G18

TYPICAL PERFORMANCE CHARACTERISTICS $T_A = 25^\circ\text{C}$ unless otherwise noted

Load Step (Automatic Burst Mode Operation)

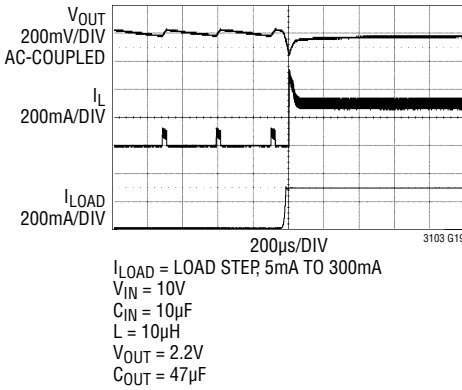

Load Step (Forced Continuous Operation)

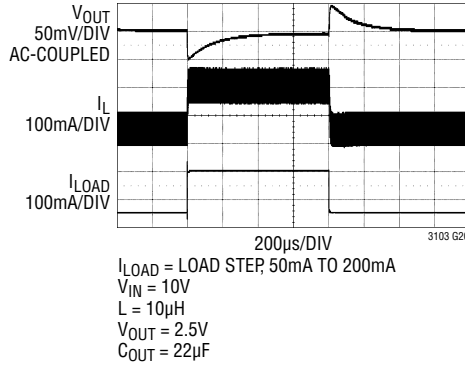

Minimum Input Voltage at Maximum Duty Cycle vs Load Current

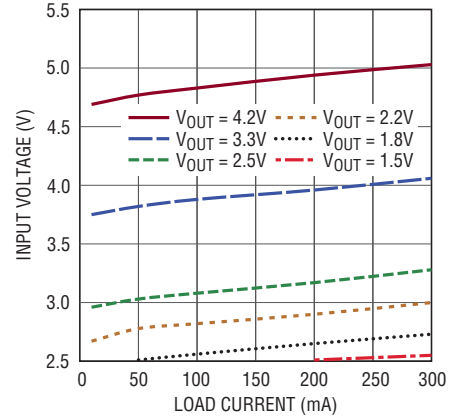

Minimum Input Voltage at Maximum Duty Cycle vs Load Current

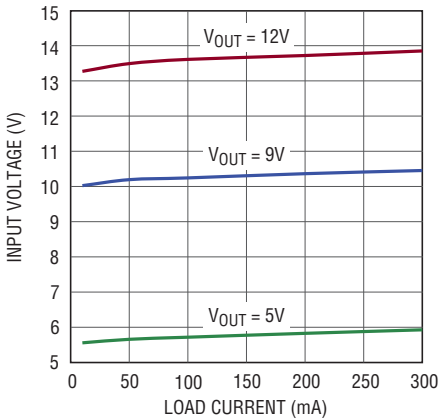

Load Regulation (Automatic Burst Mode Operation)

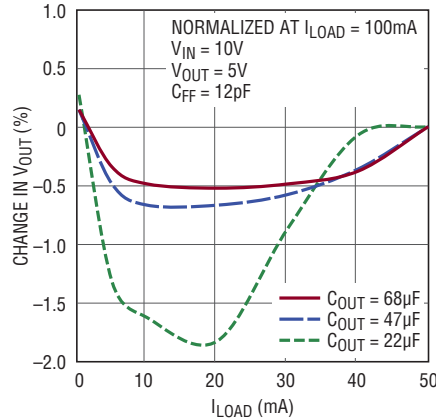

Load Regulation (Automatic Burst Mode Operation)

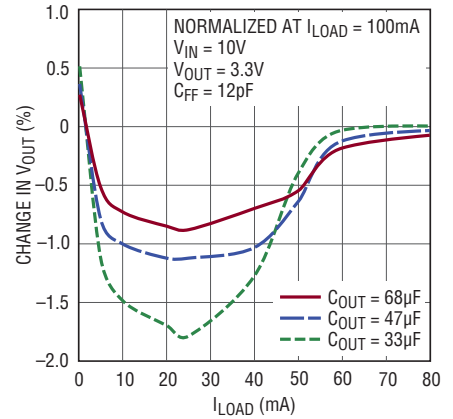

Load Regulation (Automatic Burst Mode Operation)

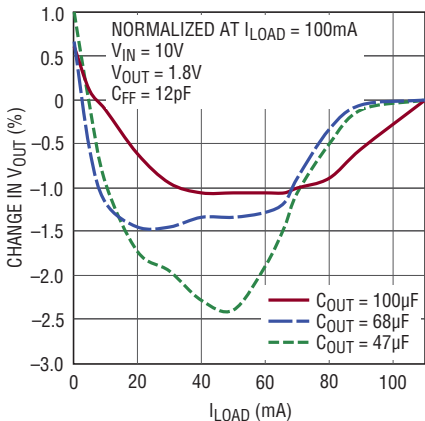

Maximum Duty Cycle vs Input Voltage

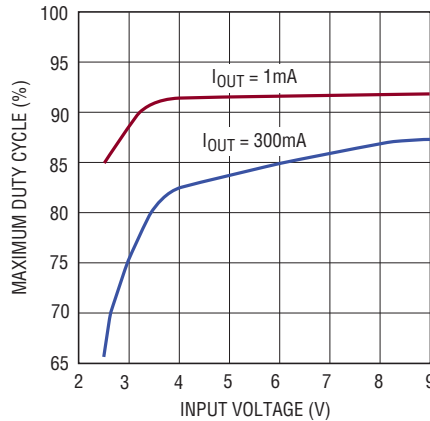

Automatic Burst Mode Threshold vs Supply Voltage

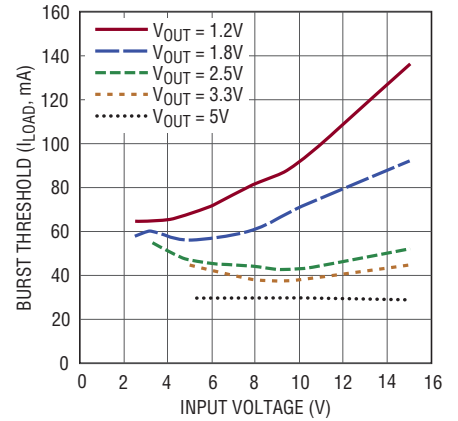

PIN FUNCTIONS

V_{IN} (Pin 1): Main Supply Pin. Decouple with a 10 μ F or larger ceramic capacitor. The capacitor should be as close to the part as possible.

SW (Pin 2): Switch Pin Connects to the Inductor. This pin connects to the drains of the internal main and synchronous power MOSFET switches.

BST (Pin 3): Bootstrapped Floating Supply for the High Side Gate Drive. Connect to SW through a 22nF (minimum) capacitor. The capacitor must be connected between BST and SW and be located as close as possible to the part as possible.

GND (Pin 4): Power Ground.

PGOOD (Pin 5): Open-drain output that is pulled to ground when the feedback voltage falls 10% (typical) below the regulation point, during a thermal shutdown event or if the converter is disabled. The PGOOD output is valid 1ms after the buck converter is enabled.

V_{CC} (Pin 6): Internally Regulated Supply Rail. Internal power rail regulated off of V_{IN} to power control circuitry. Decouple with a 1 μ F or larger ceramic capacitor placed as close to the part as possible.

RUN (Pin 7): Run Pin Comparator Input. A voltage greater than 0.85V will enable the IC. Tie this pin to V_{IN} to enable the IC or connect to an external resistor divider from V_{IN} to provide an accurate undervoltage lockout threshold. 60mV of hysteresis is provided internally.

FB (Pin 8): Feedback Input to Error Amplifier. The resistor divider connected to this pin sets the buck converter output voltage.

NC (Pin 9): No Connect Pin Must be Tied to GND.

MODE (Pin 10): Logic-Controlled Input to Select Mode of Operation. Forcing this pin high commands high efficiency automatic Burst Mode operation where the buck will automatically transition from PWM operation at heavy load to Burst Mode operation at light loads. Forcing this pin low commands low noise, fixed frequency, forced continuous operation.

GND (Exposed Pad Pin 11): Backpad Ground Common. This pad must be soldered to the PC board and connected to the ground plane for optimal thermal performance.

BLOCK DIAGRAM

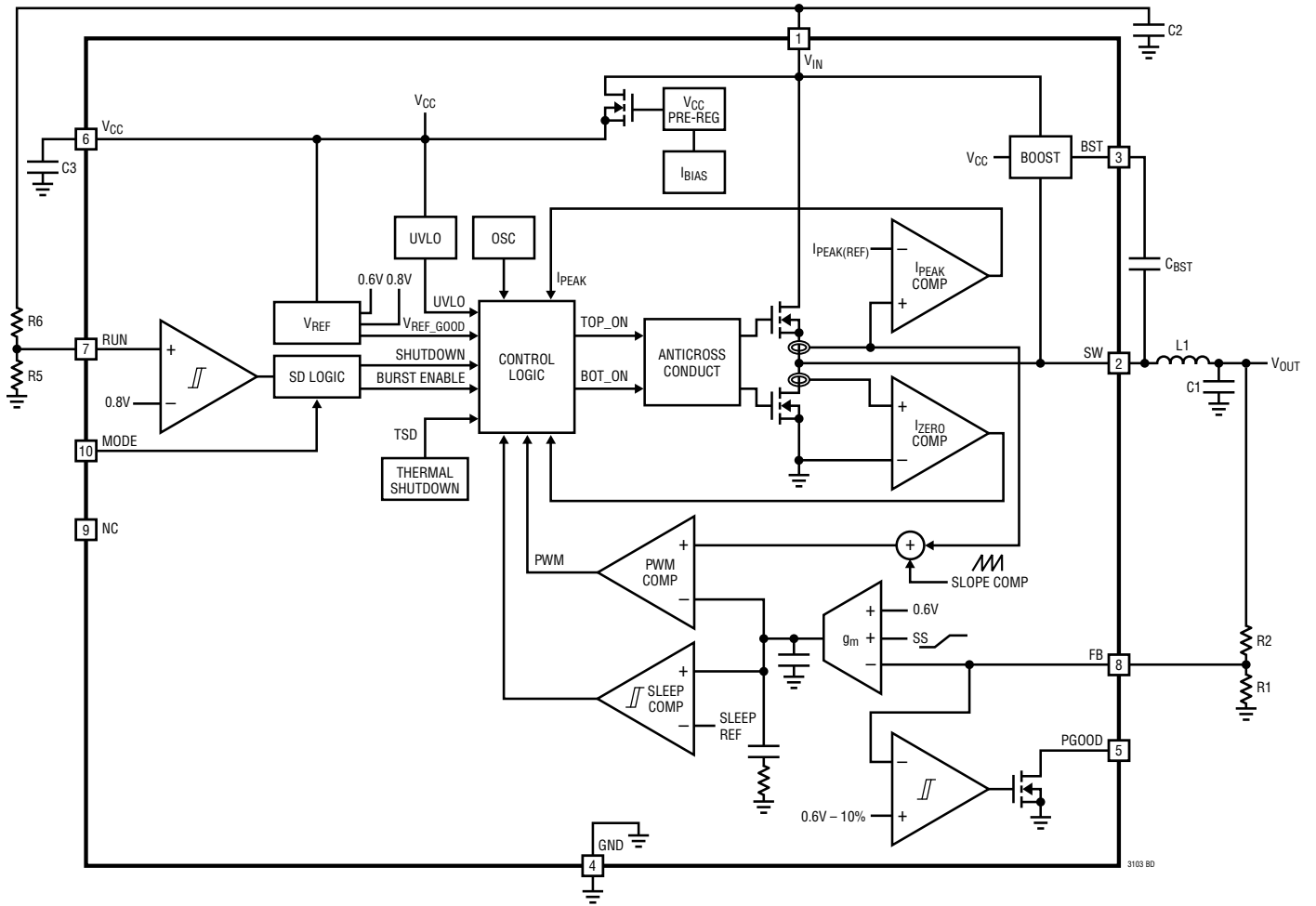

OPERATION

The LTC3103 step-down DC/DC converter is capable of supplying 300mA to the load. The output voltage is adjustable over a broad range and can be set as low as 0.6V. Both the power and the synchronous rectifier switches are internal N-channel MOSFETs. The converter uses a constant-frequency, current mode architecture and may be configured using automatic Burst Mode operation for highly efficient light load operation or configured for low noise forced conduction continuous operation where the converter is optimized to operate over a broad range of step-down ratios without pulse skipping. With the automatic Burst Mode feature enabled the typical DC supply current drops to only 1.8 μ A with no load.

Main Control Loop

During normal operation, the internal top power MOSFET is turned on at the beginning of each cycle and turned off when the PWM current comparator trips. The peak inductor current at which the comparator trips is controlled by the voltage on the output of the error amplifier. The FB pin allows the internally compensated error amplifier to receive an output feedback voltage from an external resistive divider from V_{OUT} . When the load current increases, the output begins to fall causing a slight decrease in the feedback voltage relative to the 0.6V reference, this in turn causes the control voltage to increase until the average inductor current matches the new load current. While the top MOSFET is off, the bottom MOSFET is turned on until either the inductor current starts to reverse as indicated by the current reversal comparator, I_{ZERO} , or the beginning of the next clock cycle. I_{ZERO} is set to 40mA (typical) in automatic Burst Mode operation and -110mA (typical) in forced continuous mode.

Forced Continuous Mode

Grounding MODE enables forced continuous operation and disables Burst Mode operation. At light loads, forced continuous mode minimizes output voltage ripple and noise but is less efficient than Burst Mode operation. Forced continuous operation may be desirable for use in applications that are sensitive to the Burst Mode output

voltage ripple or its harmonics. The LTC3103 offers a broad range of possible step-down ratios without pulse skipping but for very small step-down ratios, the minimum on-time of the main switch will be reached and the converter will begin turning off for multiple cycles in order to maintain regulation.

Burst Mode Operation

Holding the MODE pin above 1.2V will enable automatic Burst Mode operation and disable forced continuous operation. As the load transitions current increases the converter will automatically transition between Burst Mode and PWM operation. Conversely the converter will automatically transition from PWM operation to Burst Mode operation as the load decreases. Between bursts the converter is not active (i.e., both switches are off) and most of the internal circuitry is disabled to reduce the quiescent current to 1.8 μ A. Burst Mode entry and exit is determined by the peak inductor current and therefore the load current at which Burst Mode operation will be entered or exited depends on the input voltage, the output voltage and the inductor value. Typical curves for Burst Mode entry threshold are provided in the Typical Performance Characteristics section of this data sheet.

Soft-Start

The converter has an internal closed-loop soft-start circuit with a nominal duration of 1.4ms. The converter remains in regulation during soft-start and will therefore respond to output load transients that occur during this time. In addition, the output voltage rise time has minimal dependency on the size of the output capacitor or load current.

Thermal Shutdown

If the die temperature exceeds 150°C (typical) the converter will be disabled. All power devices will be turned off and the switch node will be forced into a high impedance state. The soft-start circuit is reset during thermal shutdown to provide a smooth recovery once the overtemperature condition is eliminated. If enabled, the converter will restart when the die temperature drops to approximately 130°C.

OPERATION

Power Good Status Output

The PGOOD pin is an open-drain output which indicates the output voltage status of the step-down converter. If the output voltage falls 10% below the regulation voltage, the PGOOD open-drain output will pull low. A built-in deglitching delay prevents false trips due to voltage transients on load steps. The output voltage must rise 2% above the falling threshold before the pull-down will turn off. The PGOOD output will also pull low during overtemperature shutdown and undervoltage lockout to indicate these fault conditions. The PGOOD output is valid 1ms after the buck converter is enabled. When the converter is disabled the open-drain device is forced on into a low impedance state. The PGOOD pull-up voltage must be below the 6V absolute maximum voltage rating of the pin.

Current Limit

The peak inductor current limit comparator shuts off the buck switch once the internal limit threshold is reached. Peak switch current is no less than 400mA.

Slope Compensation

Current mode control requires the use of slope compensation to prevent sub-harmonic oscillations in the inductor current waveform at high duty cycle operation. In some current mode ICs, current limiting is performed by clamping the error amplifier voltage to a fixed maximum which leads to a reduced output current capability at low step-down ratios. Slope compensation is accomplished on the LTC3103 internally through the addition of a compensating ramp to the current sense signal. The current limiting function is completed prior to the addition of the compensation ramp and therefore achieves a peak inductor current limit that is independent of duty cycle.

Short-Circuit Protection

When the output is shorted to ground, the error amplifier will saturate high and the high side switch will turn on at the start of each cycle and remain on until the current limit trips. During this minimum on-time, the inductor current will increase rapidly and will decrease very slowly during the remainder of the period due to the very small reverse voltage produced by a hard output short. To eliminate the possibility of inductor current runaway in this situation, the switching frequency is reduced to approximately 300kHz when the voltage on FB falls below 0.3V.

BST Pin Function

The input switch driver operates from the voltage generated on the BST pin. An external capacitor between the SW and BST pins and an internal synchronous PMOS boost switch are used to generate a voltage that is higher than the input voltage. When the synchronous rectifier is on (SW is low) the internal boost switch connects one side of the capacitor to V_{CC} replenishing its charge. When the synchronous rectifier is turned off the input switch is turned on forcing SW high and the BST pin is at a potential equal to $V_{CC} + SW$ relative to ground.

A comparator ensures there is sufficient voltage across the boost capacitor to guarantee start-up after long sleep periods or if starting up into a pre-biased output.

Undervoltage Lockout

The LTC3103 has an internal UVLO which disables the converter if the supply voltage decreases below 2.1V (typical), the converter will be disabled. The soft-start for the converter will be reset during undervoltage lockout to provide a smooth restart once the input voltage increases above the undervoltage lockout threshold. The RUN pin can alternatively be configured as a precise undervoltage lockout (UVLO) on the V_{IN} supply with a resistive divider connected to the RUN pin.

APPLICATIONS INFORMATION

The basic LTC3103 application circuit is shown as the Typical Application on the front page of this data sheet. The external component selection is determined by the desired output voltage, output current, desired noise immunity and ripple voltage requirements for each particular application. However, basic guidelines and considerations for the design process are provided in this section.

Inductor Selection

The choice of inductor value influences both the efficiency and the magnitude of the output voltage ripple. Larger inductance values will reduce inductor current ripple and will therefore lead to lower output voltage ripple. For a fixed DC resistance, a larger value inductor will yield higher efficiency by lowering the peak current to be closer to the average. However, a larger value inductor within the same family will generally have a greater series resistance, thereby offsetting this efficiency advantage. Given a desired peak-to-peak current ripple, ΔI_L (A), the required inductance can be calculated via the following expression:

$$L \geq \frac{V_{OUT}}{1.2 \cdot \Delta I_L} \cdot \left(1 - \frac{V_{OUT}}{V_{IN}} \right) (\mu H)$$

A reasonable choice for ripple current is $\Delta I_L = 120\text{mA}$ which represents 40% of the maximum 300mA load current. The DC current rating of the inductor should be at least equal to the maximum load current plus half the ripple current in order to prevent core saturation and loss of efficiency during operation. To optimize efficiency the inductor should have a low series resistance. In particularly space restricted applications it may be advantageous to use a much smaller value inductor at the expense of larger ripple current. In such cases, the converter will operate

in discontinuous conduction for a wider range of output loads and efficiency will be reduced. In addition, there is a minimum inductor value required to maintain stability of the current loop (given the fixed internal slope compensation). Specifically, if the buck converter is going to be utilized at duty cycles greater than 40%, the inductance value must be at least L_{MIN} as given by the following equation:

$$L_{MIN} \geq 2.5 \cdot V_{OUT} (\mu H)$$

Table 1 depicts the minimum required inductance for several common output voltages using standard inductor values.

Table 1. Minimum Inductance

OUTPUT VOLTAGE (V)	MINIMUM INDUCTANCE (μH)
0.8	2.2
1.2	3.3
2.0	5.6
2.7	6.8
3.3	8.3
5.0	15

A large variety of low ESR, power inductors are available that are well suited to the LTC3103 converter applications. The trade-off generally involves PCB area, application height, required output current and efficiency. Table 2 provides a representative sampling of small surface mount inductors that are well suited for use with the LTC3103. The inductor specifications listed are for comparison purposes but other values within these inductor families are generally well suited to this application as well. Within each family (i.e., at a fixed inductor size), the DC resistance generally increases and the maximum current generally decreases with increased inductance.

APPLICATIONS INFORMATION

Table 2. Representative Inductor Selection

PART NUMBER	VALUE (μH)	DCR (Ω)	MAX DC CURRENT (A)	SIZE (MM) W × L × H
Coilcraft				
EPL3015	6.8	0.19	1.00	3.0 × 3.0 × 1.5
LPS3314	10	0.33	0.70	3.3 × 3.3 × 1.3
LPS4018	15	0.26	1.12	4.0 × 4.0 × 1.8
Cooper-Bussman				
SD3114	6.8	0.30	0.98	3.1 × 3.1 × 1.4
SD3118	10	0.3	0.75	3.2 × 3.2 × 1.8
Murata				
LQH3NPN	6.8	0.20	1.25	3.0 × 3.0 × 1.4
LQH44PN	10	0.16	1.10	4.0 × 4.0 × 1.7
Sumida				
CDRH3D16	6.8	0.17	0.73	3.8 × 3.8 × 1.8
CDRH3D16	10	0.21	0.55	3.8 × 3.8 × 1.8
Taiyo-Yuden				
CBC3225	6.8	0.16	0.93	3.2 × 2.5 × 2.5
NR3015	10	0.23	0.70	3.0 × 3.0 × 1.5
NR4018	15	0.30	0.65	4.0 × 4.0 × 1.8
Würth				
744029006	6.8	0.25	0.95	2.8 × 2.8 × 1.4
744031006	6.8	0.16	0.85	3.8 × 3.8 × 1.7
744031100	10	0.19	0.74	3.8 × 3.8 × 1.7
744031100	15	0.26	0.62	3.8 × 3.8 × 1.7
Panasonic				
ELLVGG6R8N	6.8	0.23	1.00	3.0 × 3.0 × 1.5
ELL4LG100MA	10	0.20	0.80	3.8 × 3.8 × 1.8
TDK				
VLF3012	6.8	0.18	0.78	3.0 × 2.8 × 1.2
VLC4018	10	0.16	0.85	4.0 × 4.0 × 1.8

Output Capacitor Selection

A low ESR output capacitor should be utilized at the buck output in order to minimize voltage ripple. Multilayer ceramic capacitors are an excellent choice as they have low ESR and are available in small footprints. In addition to controlling the output ripple magnitude, the value of the output capacitor also sets the loop crossover frequency and therefore can impact loop stability. There is both a minimum and maximum capacitance value required to ensure stability of the loop. If the output capacitance is too small, the loop crossover frequency will increase to

the point where switching delay and the high frequency parasitic poles of the error amplifier will degrade the phase margin. In addition, the wider bandwidth produced by a small output capacitor will make the loop more susceptible to switching noise. At the other extreme, if the output capacitor is too large, the crossover frequency can decrease too far below the compensation zero and also lead to degraded phase margin. Table 3 provides a guideline for the range of allowable values of low ESR output capacitors assuming a feedforward capacitor is used. See the Output Voltage Programming section for details on selecting a feedforward capacitor. Larger value output capacitors can be accommodated provided they have sufficient ESR to stabilize the loop, or by increasing the value of the feedforward capacitor in parallel with the upper resistor divider resistor.

In Burst Mode operation, the output capacitor stores energy to satisfy the load current when the LTC3103 is in a low current sleep state between the burst pulses. It can take several cycles to respond to a large load step during a sleep period. If large transient load currents are required then a larger capacitor can be used at the output to minimize output voltage droop until the part transitions from Burst Mode operation to continuous mode operation.

Note that even X5R and X7R type ceramic capacitors have a DC bias effect which reduces their capacitance when a DC voltage is applied. It is not uncommon for capacitors offered in the smallest case sizes to lose more than 50% of their capacitance when operated near their rated voltage. As a result it is sometimes necessary to use a larger capacitance value or use a higher voltage rating in order to realize the intended capacitance value. Consult the manufacturer's data for the capacitor you select to be assured of having the necessary capacitance in your application.

Table 3. Recommended Output Capacitor Limits

OUTPUT VOLTAGE (V)	C _{MIN} (μF)	C _{MAX} (μF)
0.8	22.0	220
1.2	15.0	220
2.0	12.0	100
2.7	6.8	68
3.3	4.7	47
5.0	4.7	47

APPLICATIONS INFORMATION

Input Capacitor Selection

The V_{IN} pin provides current to the power stages of the buck converter. It is recommended that a low ESR ceramic capacitor with a value of at least $10\mu\text{F}$ be used to bypass the pin. These capacitors should be placed as close to the pin as possible and should have a short return path to the GND pin.

Output Voltage Programming

The output voltage is set by a resistive divider according to the following formula:

$$V_{OUT} = 0.6V \cdot \left(1 + \frac{R2}{R1} \right)$$

The external divider is connected to the output as shown in Figure 1. Note that FB divider current is not included in the LTC3103 quiescent current specification. For improved transient response, a feedforward capacitor, C_{FF} , may be placed in parallel with resistor R2. The capacitor modifies the loop dynamics by adding a pole-zero pair to the loop dynamics which generates a phase boost that can improve the phase margin and increase the speed of the transient response, resulting in smaller voltage deviation on load transients. The zero frequency depends not only on the value of the feed forward capacitor, but also on the upper resistor divider resistor. Specifically, the zero frequency, f_{ZERO} , is given by the following equation:

$$f_{ZERO} = \frac{1}{2 \cdot \pi \cdot R2 \cdot C_{FF}}$$

For R2 resistor values of $\sim 1\text{M}$ a 12pF ceramic capacitor will suffice, however that value may be increased or decreased to optimize the converter's response for a given set of application parameters. In a Burst Mode application for instance, a $C_{FF} = 27\text{pF}$ will lower output voltage ripple at light load.

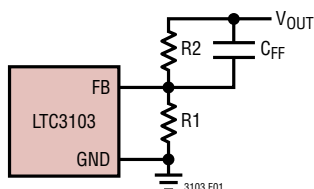

Figure 1. Setting the Output Voltage

Minimum Off-Time/On-Time Considerations

The maximum duty cycle is limited in the LTC3103 by the boost capacitor refresh time, the rise/fall times of the switch as well as propagation delays in the PWM comparator, the level shifts and the gate drive. This minimum off time is typically 65ns which imposes a maximum duty cycle of:

$$DC_{MAX} = 1 - (f \cdot t_{OFF(MIN)})$$

where f is the 1.2MHz switching frequency and $t_{OFF(MIN)}$ is the minimum off-time. If the maximum duty cycle is surpassed, due to a dropping input voltage for example, the output will drop out of regulation. The minimum input voltage to avoid this dropout condition is:

$$V_{IN(MIN)} = \frac{V_{OUT}}{1 - (f \cdot t_{OFF(MIN)})}$$

Conversely, the minimum on-time is the smallest duration of time in which the buck switch can be in its "on" state. This time is limited by similar factors and is typically 70ns . In forced continuous operation, the minimum on-time limit imposes a minimum duty cycle of:

$$DC_{MIN} = f \cdot t_{ON(MIN)}$$

where $t_{ON(MIN)}$ is the minimum on-time. In extreme step-down ratios where the minimum duty cycle is surpassed, the output voltage will still be in regulation but the rectifier switch will remain on for more than one cycle and sub-harmonic switching will occur to provide a higher effective duty cycle. The result is higher output voltage ripple. This is an acceptable result in many applications so this constraint may not be of critical importance in some cases.

Precise Undervoltage Lockout

The LTC3103 is in shutdown when the RUN pin is low and active when the pin is higher than the RUN pin threshold. The rising threshold of the RUN pin comparator is an accurate 0.8V , with 60mV of hysteresis. This threshold is enabled when V_{IN} is above the 2.5V minimum value. If V_{IN} is lower than 2.5V , an internal undervoltage monitor puts the part in shutdown independent of the RUN pin state.

The RUN pin can be configured as a precise undervoltage lockout (UVLO) on the V_{IN} supply with a resistive divider

APPLICATIONS INFORMATION

connected to the RUN pin as shown in Figure 2 to meet specific V_{IN} voltage requirements. If used, note that the external divider current is not included in the LTC3103 quiescent current specification.

The rising UVLO threshold can be calculated using the following equation:

$$V_{UVLO} = 0.8V \cdot \left(1 + \frac{R4}{R3} \right)$$

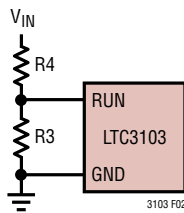

Figure 2. Setting the Undervoltage Lockout Threshold

Internal V_{CC} Regulator

The LTC3103 uses an internal NMOS source follower regulator off of V_{IN} to generate a low voltage internal rail, V_{CC} . The regulator is designed to deliver current only to the internal drivers and other internal control circuits and not to an external load. The V_{CC} pin should be bypassed with a $1\mu F$ or larger ceramic capacitor.

Boost Capacitor Selection

The LTC3103 uses a bootstrapped supply to power the buck switch gate drivers. When the synchronous rectifier turns on, an internal PMOS switch turns on synchronously to charge the boost capacitor, C_{BST} , to the voltage on V_{CC} . For most applications a $0.022\mu F$ will suffice. The capacitor should be placed as close to their respective pins as possible.

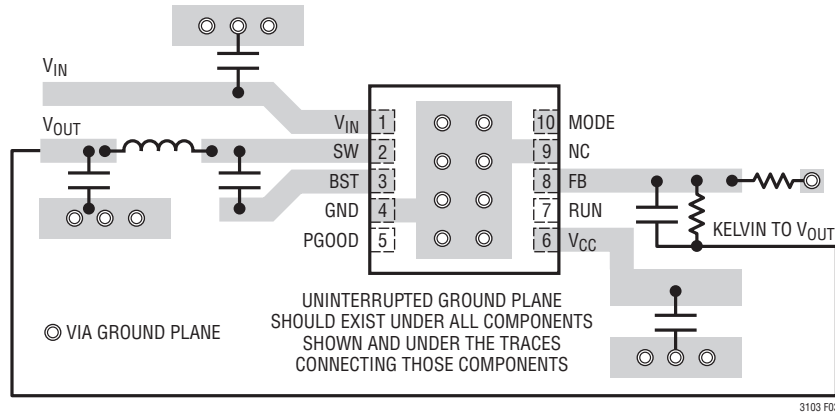
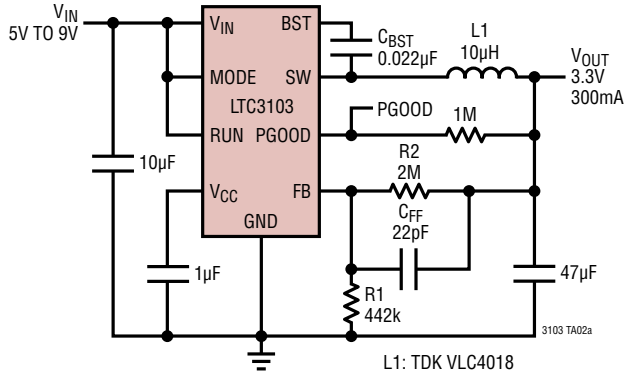

Figure 3. PCB Layout Recommendations

TYPICAL APPLICATIONS

Portable LF RFID Reader, Dual Lithium-Ion to 3.3V/300mA Regulator with Ultralow I_Q



Efficiency vs Output Current

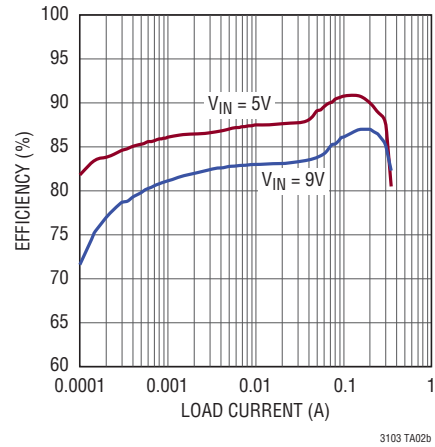

12V to 2.2V/300mA Regulator with 9V Accurate UVL

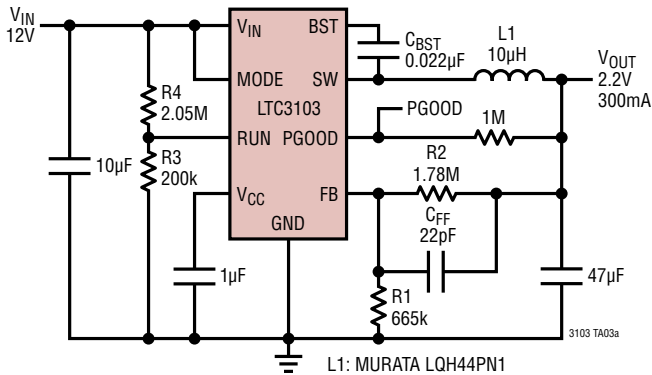

Start-Up with Ramped Input Power

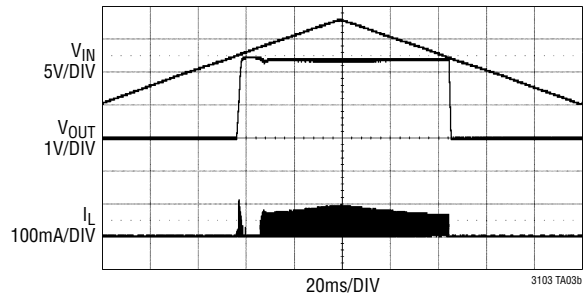

TYPICAL APPLICATIONS

Solar-Powered 2.2V Supply with Li Battery Backup and Run Threshold Set to Battery Minimum Voltage

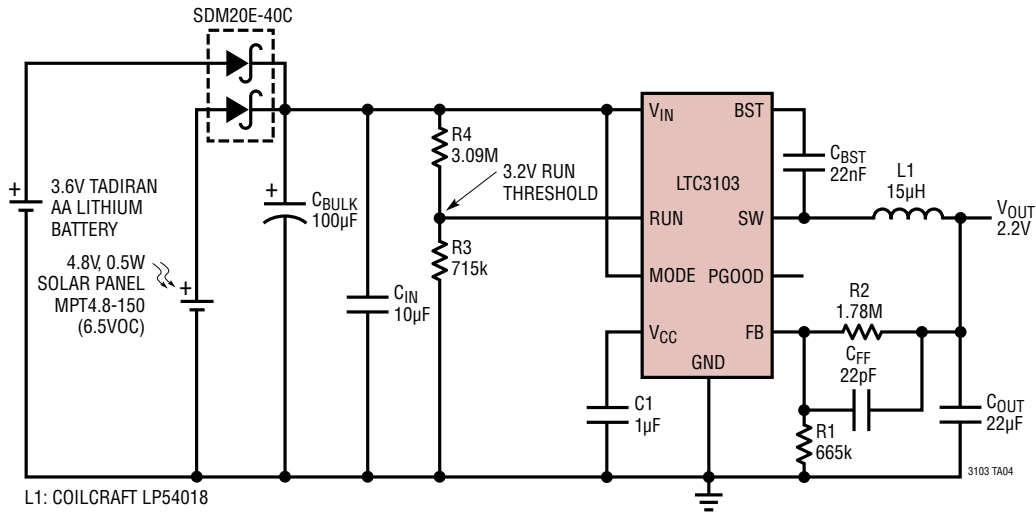

5V to 1.2V/300mA Low Noise Regulator Using Forced Continuous Operation

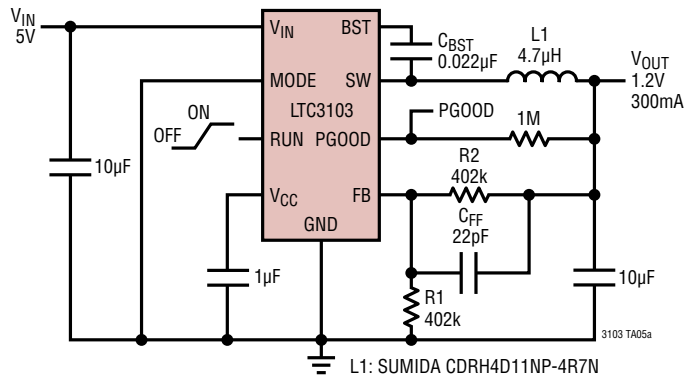

Efficiency vs Output Current

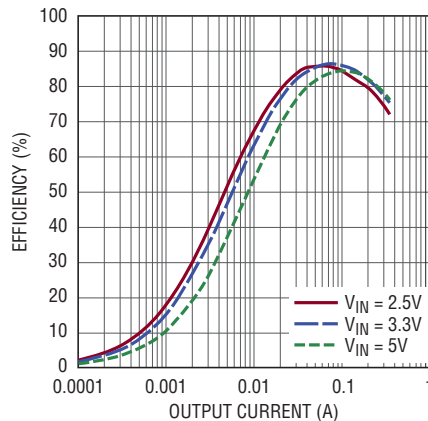

3103 TA05b

3103fa

PACKAGE DESCRIPTION

Please refer to <http://www.linear.com/product/LTC3103#packaging> for the most recent package drawings.

DD Package 10-Lead Plastic DFN (3mm × 3mm) (Reference LTC DWG # 05-08-1699 Rev C)

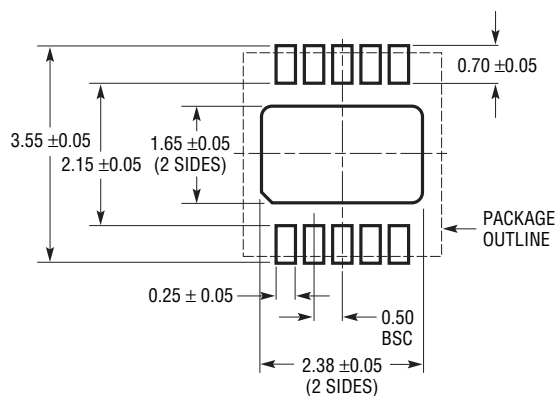

RECOMMENDED SOLDER PAD PITCH AND DIMENSIONS

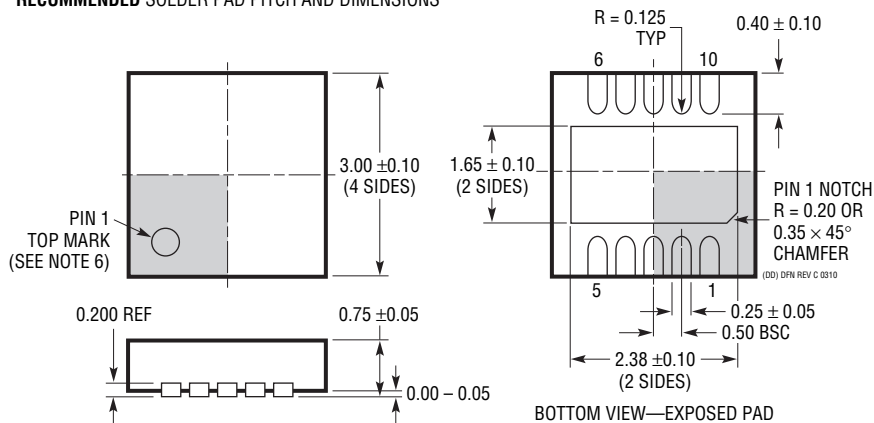

NOTE:

- DRAWING TO BE MADE A JEDEC PACKAGE OUTLINE M0-229 VARIATION OF (WEED-2). CHECK THE LTC WEBSITE DATA SHEET FOR CURRENT STATUS OF VARIATION ASSIGNMENT
- DRAWING NOT TO SCALE
- ALL DIMENSIONS ARE IN MILLIMETERS
- DIMENSIONS OF EXPOSED PAD ON BOTTOM OF PACKAGE DO NOT INCLUDE MOLD FLASH. MOLD FLASH, IF PRESENT, SHALL NOT EXCEED 0.15mm ON ANY SIDE
- EXPOSED PAD SHALL BE SOLDER PLATED
- SHADED AREA IS ONLY A REFERENCE FOR PIN 1 LOCATION ON THE TOP AND BOTTOM OF PACKAGE

PACKAGE DESCRIPTION

Please refer to <http://www.linear.com/product/LTC3103#packaging> for the most recent package drawings.

MSE Package 10-Lead Plastic MSOP, Exposed Die Pad (Reference LTC DWG # 05-08-1664 Rev I)

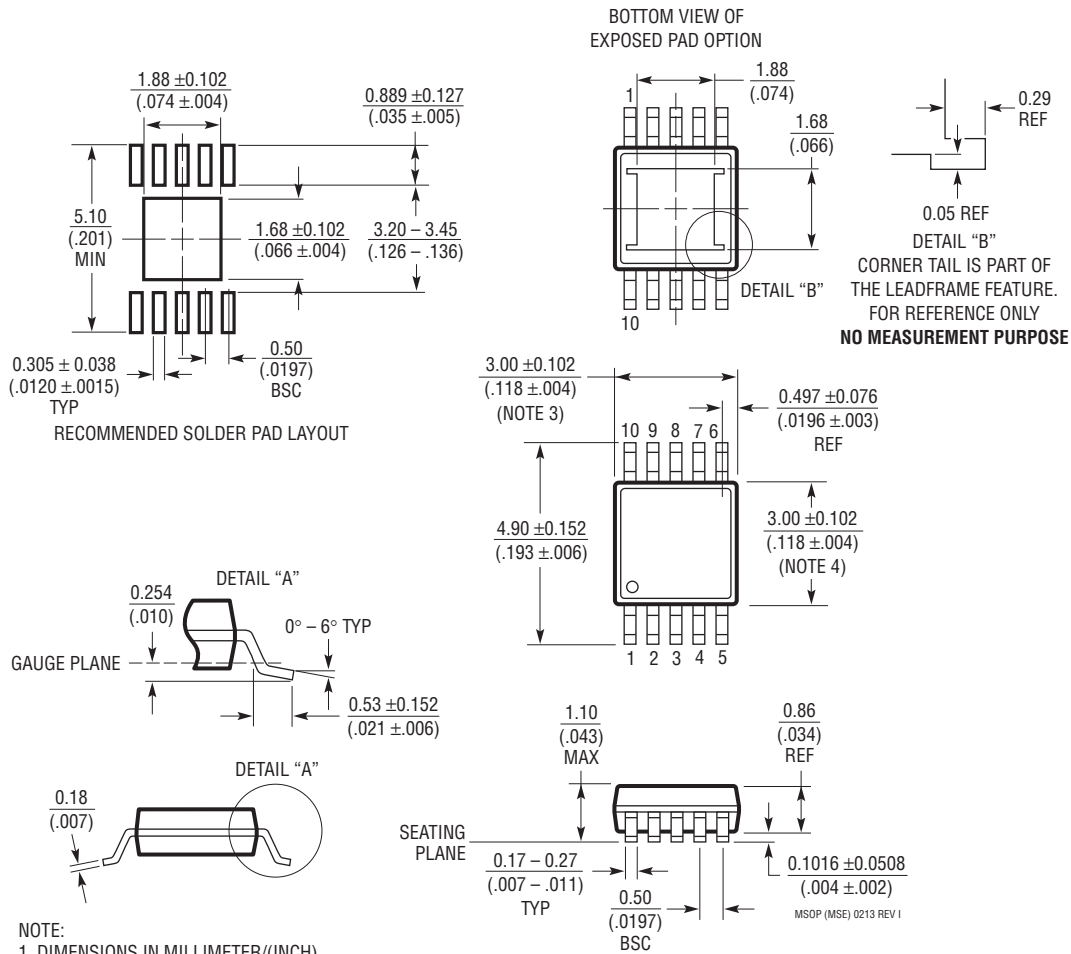

NOTE:

1. DIMENSIONS IN MILLIMETER/(INCH)
2. DRAWING NOT TO SCALE
3. DIMENSION DOES NOT INCLUDE MOLD FLASH, PROTRUSIONS OR GATE BURRS.
MOLD FLASH, PROTRUSIONS OR GATE BURRS SHALL NOT EXCEED 0.152mm (.006") PER SIDE
4. DIMENSION DOES NOT INCLUDE INTERLEAD FLASH OR PROTRUSIONS.
INTERLEAD FLASH OR PROTRUSIONS SHALL NOT EXCEED 0.152mm (.006") PER SIDE
5. LEAD COPLANARITY (BOTTOM OF LEADS AFTER FORMING) SHALL BE 0.102mm (.004") MAX
6. EXPOSED PAD DIMENSION DOES INCLUDE MOLD FLASH. MOLD FLASH ON E-PAD SHALL NOT EXCEED 0.254mm (.010") PER SIDE.

REVISION HISTORY

REV	DATE	DESCRIPTION	PAGE NUMBER
A	07/16	Updated Typical Application circuit.	1
		Updated Input Voltage Range condition to include After Start-Up. Added another line for Start-Up.	2
		Updated Soft-Start Time condition to include $V_{IN} = 5V$.	3
		Corrected G04 to remove LDO ENABLED	4
		Replaced G13.	5
		Corrected RUN Pin Function description.	7
		Replaced Block Diagram, V_{CC} regulator pass element PMOS with NMOS.	8
		Updated Application Information.	13
		Updated both application circuits.	15
		Updated applications title.	16
		Updated application circuit.	20

TYPICAL APPLICATION

12V to 5V/300mA Regulator with High Efficiency, Ultralow I_Q
(1.8 μ A with V_{OUT} in Regulation, No Load)

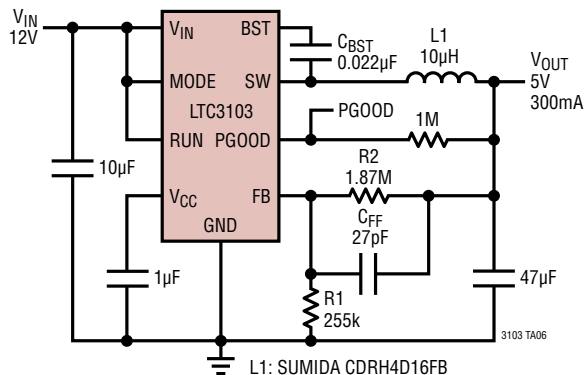

RELATED PARTS

PART NUMBER	DESCRIPTION	COMMENTS
LTC3104	15V, 300mA Synchronous Step-Down DC/DC Converter with Ultralow Quiescent Current and 10mA LDO	V_{IN} : 2.5V to 15V, $V_{OUT(MIN)}$ = 0.6V, I_Q = 2.8 μ A, I_{SD} = 1 μ A, 3mm \times 3mm DFN-10, MSOP-10
LTC3642	45V (Transient to 60V) 50mA Synchronous Step-Down DC/DC Converter	V_{IN} : 4.5V to 45V, $V_{OUT(MIN)}$ = 0.8V, I_Q = 12 μ A, I_{SD} < 1 μ A, 3mm \times 3mm DFN-8, MSOP-8
LTC3631	45V (Transient to 60V) 100mA Synchronous Step-Down DC/DC Converter	V_{IN} : 4.5V to 45V, $V_{OUT(MIN)}$ = 0.8V, I_Q = 12 μ A, I_{SD} < 1 μ A, 3mm \times 3mm DFN-8, MSOP-8
LTC3632	50V (Transient to 60V) 20mA Synchronous Step-Down DC/DC Converter	V_{IN} : 4.5V to 50V, $V_{OUT(MIN)}$ = 0.8V, I_Q = 12 μ A, I_{SD} < 1 μ A, 3mm \times 3mm DFN-8, MSOP-8
LTC3388-1/LTC3388-3	20V, 50mA High Efficiency Nano Power Step-Down Regulators	V_{IN} : 2.7V to 20V, $V_{OUT(MIN)}$ Fixed 1.1V to 5.5V, I_Q = 720nA, I_{SD} = 400nA, 3mm \times 3mm DFN-10, MSOP-10
LTC3108/LTC3108-1	Ultralow Voltage Step-Up Converter and Power Managers	V_{IN} : 0.02V to 1V, $V_{OUT(MIN)}$ Fixed 2.35V to 5V, I_Q = 6 μ A, I_{SD} < 1 μ A, 3mm \times 4mm DFN-12, SSOP-16
LTC3109	Auto-Polarity, Ultralow Voltage Step-Up Converter and Power Manager	V_{IN} : 0.03V to 1V, $V_{OUT(MIN)}$ Fixed 2.35V to 5V, I_Q = 7 μ A, I_{SD} < 1 μ A, 4mm \times 4mm QFN-20, SSOP-20
LTC4071	Li-Ion/Polymer Shunt Battery Charger System with Low Battery Disconnect	Charger Plus Pack Protection in One IC Low Operating Current (550nA), 50mA Internal Shunt Current, Pin Selectable Float Voltages (4.0V, 4.1V, 4.2V), 8-Lead, 2mm \times 3mm, DFN and MSOP Packages
LTC4070	Li-Ion/Polymer Low Current Shunt Battery Charger System	Selectable V_{FLOAT} = 4.0V, 4.1V, 4.2V, Max Shunt Current = 50mA, I_{CCQ} = 450nA to 1.04mA, I_{CCQLB} = 300nA, 2mm \times 3mm DFN-8, MSOP-8
LTC1877	10V, 600mA High Efficiency Synchronous Step-Down DC/DC Converter	V_{IN} : 2.65V to 10V, $V_{OUT(MIN)}$ = 0.8V, I_Q = 10 μ A, I_{SD} < 1 μ A, MSOP-8
LTC3105	5V, 400mA, MPDC Step-Up Converter with 250mV Start-Up	V_{IN} : 0.225V to 5V, $V_{OUT(MAX)}$ = 5.25V, I_Q = 24 μ A, I_{SD} = 10 μ A, 3mm \times 3mm DFN-10, MSOP-12